

MANUFACTURE OF THE PROPRIETARY PARTS SHOWN HERE WITHOUT WRITTEN CONSENT IS ABSOLUTELY PROHIBITED

THIS DRAWING EMBODIES A CONFIDENTIAL, PROPRIETARY DESIGN & ALL DESIGN, MANUFACTURING PRODUCTION, USE & SALE RIGHTS REGARDING SAME ARE EXPRESSLY RESERVED.

PROJECT NUMBER: 91-091  
S45584

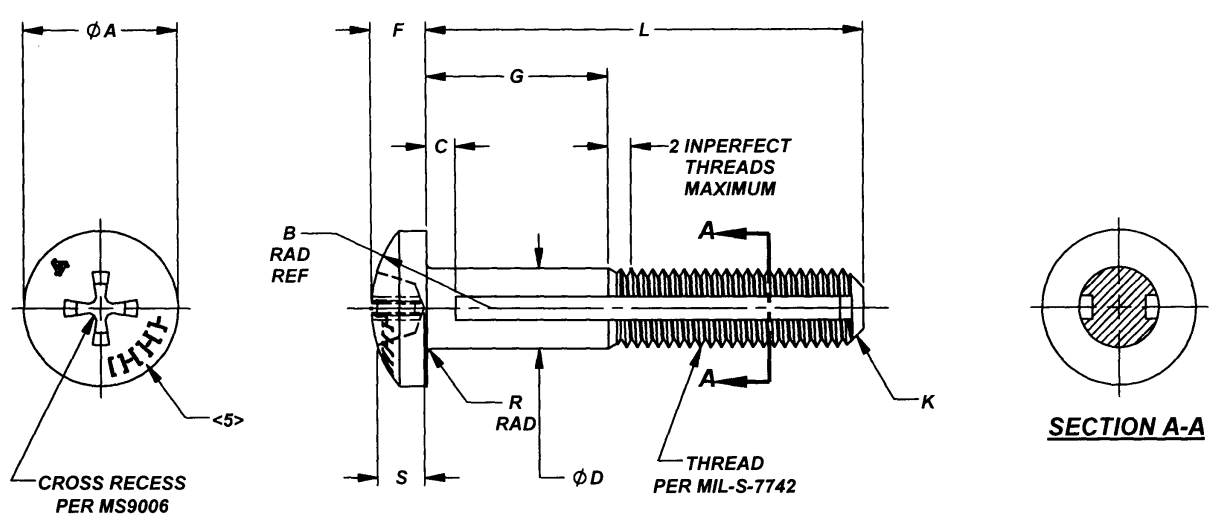

**TABLE 1**

FIRST DASH NUMBER	THREAD SIZE	ØA	B RAD REF	C MAX	ØD	F	G GRIP	K x 45° APPROX.	R RAD	S MAX	L LENGTH	ULTIMATE TENSILE STRENGTH MINIMUM <9>	ULTIMATE SHEAR STRENGTH MINIMUM <9>
-06	.1380-32 UNC-3A	.270 .256	.20	.050	.1375 .1365	.097 .087	SEE SHEETS 2, 3 & 4	.030	.015 .005	.091	SEE SHEETS 2, 3 & 4	1,020 LBS	630 LBS
-08	.1640-32 UNC-3A	.322 .306	.24	.050	.1635 .1625	.115 .105		.030	.010 .020	.097		1,600 LBS	980 LBS
-10	.1900-32 UNF-3A	.373 .357	.28	.050	.1895 .1885	.133 .122		.030	.010 .020	.113		2,350 LBS	1,440 LBS
-4	.2500-28 UNF-3A	.492 .473	.37	.050	.2495 .2485	.175 .162		.035	.010 .020	.144		4,470 LBS	2,740 LBS
-5	.3125-24 UNF-3A	.615 .594	.53	.065	.3120 .3110	.218 .203		.040	.010 .020	.173		7,160 LBS	4,390 LBS
-6	.3750-24 UNF-3A	.740 .716	.65	.065	.3745 .3735	.261 .244		.040	.015 .025	.213		11,020 LBS	6,750 LBS

**NOTES; UNLESS OTHERWISE SPECIFIED:**

- MATERIAL: 17-4PH CRES PER AMS5643.
- HEAT TREAT: CONDITION H1025 PER AMS2759.
- FINISH: PASSIVATED PER AMS2700.
- HEAD: PAN HEAD PER NAS1635.
- PART MARKING: HEAD OF SCREW TO BE MARKED WITH TRIDAIR LOGO, FIRST SECOND AND THIRD DASH NUMBERS DEPRESSED .010 MAXIMUM DEEP.
- SCREW TO BE USED WITH CA2210-()R RETAINING RING TO CAPTIVATE TO PANEL.
- PANEL PREPARATION: REFER TO CAL-STD-0260.
- INSTALLATION: REFER TO TRIDAIR DRAWING NUMBER CA2210T-().
- TENSILE AND SHEAR STRENGTHS ARE CALCULATED VALUES.

**10. PART CALLOUT EXAMPLE:**

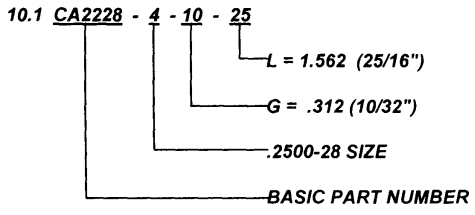

INTERIM DOCUMENT REVISION		
Rev.	Date	DAF#
A1	10/8/2018	117431

APPROVED DATE 4 MAR 91	CURRENT DESIGN ACTIVITY: <b>ARCONIC</b> Arconic Fastening Systems	TITLE: <b>SCREW, CAPTIVE, PAN HEAD, CRES, 155 KSI</b>	CURRENT DESIGN ACTIVITY: <b>CAGE CODE: 29372</b>
REV. LETTER AND DATE <b>A</b> 19 JUL 16	<b>TRIDAIR PRODUCTS</b> 3000 W. LOMITA BLVD. TORRANCE, CA. 90505	UNLESS OTHERWISE SPECIFIED DIMENSIONS ARE IN INCHES & ASME Y14.5M TOLERANCES:	<b>SALES DRAWING NO.</b>  <b>CA2228-()-()-()</b>
DAF NUMBER DAF 114534		ANGLES = ±3' DECIMALS .XX = ±.02 .XXX = ±.010	<b>SHEET 1 OF 4</b>

MANUFACTURE OF THE PROPRIETARY PARTS SHOWN HERE WITHOUT WRITTEN CONSENT IS ABSOLUTELY PROHIBITED

**TABLE 2**

<b>.1380-32 SIZE FIRST DASH NUMBER -06</b>									
<b>G GRIP</b>									<b>L LENGTH</b>
<b>.062</b>	<b>.094</b>	<b>.125</b>	<b>.156</b>	<b>.187</b>	<b>.218</b>	<b>.250</b>	<b>.281</b>	<b>.312</b>	
-2-7	-3-7	-4-7	-5-7	-6-7	-7-7	-8-7	-9-7	-10-7	.437
-2-8	-3-8	-4-8	-5-8	-6-8	-7-8	-8-8	-9-8	-10-8	.500
-2-9	-3-9	-4-9	-5-9	-6-9	-7-9	-8-9	-9-9	-10-9	.562
-2-10	-3-10	-4-10	-5-10	-6-10	-7-10	-8-10	-9-10	-10-10	.625
-2-11	-3-11	-4-11	-5-11	-6-11	-7-11	-8-11	-9-11	-10-11	.687
-2-12	-3-12	-4-12	-5-12	-6-12	-7-12	-8-12	-9-12	-10-12	.750
-2-13	-3-13	-4-13	-5-13	-6-13	-7-13	-8-13	-9-13	-10-13	.812
-2-14	-3-14	-4-14	-5-14	-6-14	-7-14	-8-14	-9-14	-10-14	.875
-2-15	-3-15	-4-15	-5-15	-6-15	-7-15	-8-15	-9-15	-10-15	.937
-2-16	-3-16	-4-16	-5-16	-6-16	-7-16	-8-16	-9-16	-10-16	1.000
-2-17	-3-17	-4-17	-5-17	-6-17	-7-17	-8-17	-9-17	-10-17	1.062
-2-18	-3-18	-4-18	-5-18	-6-18	-7-18	-8-18	-9-18	-10-18	1.125
-2-19	-3-19	-4-19	-5-19	-6-19	-7-19	-8-19	-9-19	-10-19	1.187
-2-20	-3-20	-4-20	-5-20	-6-20	-7-20	-8-20	-9-20	-10-20	1.250
-2-21	-3-21	-4-21	-5-21	-6-21	-7-21	-8-21	-9-21	-10-21	1.312
-2-22	-3-22	-4-22	-5-22	-6-22	-7-22	-8-22	-9-22	-10-22	1.375
-2-23	-3-23	-4-23	-5-23	-6-23	-7-23	-8-23	-9-23	-10-23	1.437
-2-24	-3-24	-4-24	-5-24	-6-24	-7-24	-8-24	-9-24	-10-24	1.500
-2-25	-3-25	-4-25	-5-25	-6-25	-7-25	-8-25	-9-25	-10-25	1.562
-2-26	-3-26	-4-26	-5-26	-6-26	-7-26	-8-26	-9-26	-10-26	1.625
-2-27	-3-27	-4-27	-5-27	-6-27	-7-27	-8-27	-9-27	-10-27	1.687
-2-28	-3-28	-4-28	-5-28	-6-28	-7-28	-8-28	-9-28	-10-28	1.750

**TABLE 3**

<b>.1640-32 SIZE FIRST DASH NUMBER -08</b>									
<b>G GRIP</b>									<b>L LENGTH</b>
<b>.062</b>	<b>.094</b>	<b>.125</b>	<b>.156</b>	<b>.187</b>	<b>.218</b>	<b>.250</b>	<b>.281</b>	<b>.312</b>	
-2-7	-3-7	-4-7	-5-7	-6-7	-7-7	-8-7	-9-7	-10-7	.437
-2-8	-3-8	-4-8	-5-8	-6-8	-7-8	-8-8	-9-8	-10-8	.500
-2-9	-3-9	-4-9	-5-9	-6-9	-7-9	-8-9	-9-9	-10-9	.562
-2-10	-3-10	-4-10	-5-10	-6-10	-7-10	-8-10	-9-10	-10-10	.625
-2-11	-3-11	-4-11	-5-11	-6-11	-7-11	-8-11	-9-11	-10-11	.687
-2-12	-3-12	-4-12	-5-12	-6-12	-7-12	-8-12	-9-12	-10-12	.750
-2-13	-3-13	-4-13	-5-13	-6-13	-7-13	-8-13	-9-13	-10-13	.812
-2-14	-3-14	-4-14	-5-14	-6-14	-7-14	-8-14	-9-14	-10-14	.875
-2-15	-3-15	-4-15	-5-15	-6-15	-7-15	-8-15	-9-15	-10-15	.937
-2-16	-3-16	-4-16	-5-16	-6-16	-7-16	-8-16	-9-16	-10-16	1.000
-2-17	-3-17	-4-17	-5-17	-6-17	-7-17	-8-17	-9-17	-10-17	1.062
-2-18	-3-18	-4-18	-5-18	-6-18	-7-18	-8-18	-9-18	-10-18	1.125
-2-19	-3-19	-4-19	-5-19	-6-19	-7-19	-8-19	-9-19	-10-19	1.187
-2-20	-3-20	-4-20	-5-20	-6-20	-7-20	-8-20	-9-20	-10-20	1.250
-2-21	-3-21	-4-21	-5-21	-6-21	-7-21	-8-21	-9-21	-10-21	1.312
-2-22	-3-22	-4-22	-5-22	-6-22	-7-22	-8-22	-9-22	-10-22	1.375
-2-23	-3-23	-4-23	-5-23	-6-23	-7-23	-8-23	-9-23	-10-23	1.437
-2-24	-3-24	-4-24	-5-24	-6-24	-7-24	-8-24	-9-24	-10-24	1.500
-2-25	-3-25	-4-25	-5-25	-6-25	-7-25	-8-25	-9-25	-10-25	1.562
-2-26	-3-26	-4-26	-5-26	-6-26	-7-26	-8-26	-9-26	-10-26	1.625
-2-27	-3-27	-4-27	-5-27	-6-27	-7-27	-8-27	-9-27	-10-27	1.687
-2-28	-3-28	-4-28	-5-28	-6-28	-7-28	-8-28	-9-28	-10-28	1.750

THIS DRAWING EMBODIES A CONFIDENTIAL, PROPRIETARY DESIGN & ALL DESIGN, MANUFACTURING PRODUCTION, USE & SALE RIGHTS REGARDING SAME ARE EXPRESSLY RESERVED.

<b>INTERIM DOCUMENT REVISION</b>		
Rev.	Date	DAF#
A1	10/8/2018	117431

PROJECT NUMBER: 91-091  
S45584

APPROVED DATE <b>4 MAR 91</b>	CURRENT DESIGN ACTIVITY:  <b>ARCONIC</b> Arconic Fastening Systems	TITLE: <b>SCREW, CAPTIVE, PAN HEAD,                  CRES, 155 KSI</b>	CURRENT DESIGN ACTIVITY: <b>CAGE CODE: 29372</b> <b>SALES DRAWING NO.</b> <b>CA2228-()-()-()</b>
REV. LETTER AND DATE <b>A 19 JUL 16</b>	TRIDAIR PRODUCTS 3000 W. LOMITA BLVD. TORRANCE, CA, 90505	UNLESS OTHERWISE SPECIFIED DIMENSIONS ARE IN INCHES & ASME Y14.5M TOLERANCES:	ANGLES DECIMALS = ±3° .XX = ±.02 .XXX = ±.010
DAF NUMBER <b>DAF 114534</b>			SHEET 2 OF 4

MANUFACTURE OF THE PROPRIETARY PARTS SHOWN HERE WITHOUT WRITTEN CONSENT IS ABSOLUTELY PROHIBITED

**TABLE 4**

.1900-32 SIZE FIRST DASH NUMBER -10									
G GRIP									L LENGTH
.062	.094	.125	.156	.187	.218	.250	.281	.312	
- 2 - 7	- 3 - 7	- 4 - 7	- 5 - 7	- 6 - 7	- 7 - 7	- 8 - 7	- 9 - 7	- 10 - 7	.437
- 2 - 8	- 3 - 8	- 4 - 8	- 5 - 8	- 6 - 8	- 7 - 8	- 8 - 8	- 9 - 8	- 10 - 8	.500
- 2 - 9	- 3 - 9	- 4 - 9	- 5 - 9	- 6 - 9	- 7 - 9	- 8 - 9	- 9 - 9	- 10 - 9	.562
- 2 - 10	- 3 - 10	- 4 - 10	- 5 - 10	- 6 - 10	- 7 - 10	- 8 - 10	- 9 - 10	- 10 - 10	.625
- 2 - 11	- 3 - 11	- 4 - 11	- 5 - 11	- 6 - 11	- 7 - 11	- 8 - 11	- 9 - 11	- 10 - 11	.687
- 2 - 12	- 3 - 12	- 4 - 12	- 5 - 12	- 6 - 12	- 7 - 12	- 8 - 12	- 9 - 12	- 10 - 12	.750
- 2 - 13	- 3 - 13	- 4 - 13	- 5 - 13	- 6 - 13	- 7 - 13	- 8 - 13	- 9 - 13	- 10 - 13	.812
- 2 - 14	- 3 - 14	- 4 - 14	- 5 - 14	- 6 - 14	- 7 - 14	- 8 - 14	- 9 - 14	- 10 - 14	.875
- 2 - 15	- 3 - 15	- 4 - 15	- 5 - 15	- 6 - 15	- 7 - 15	- 8 - 15	- 9 - 15	- 10 - 15	.937
- 2 - 16	- 3 - 16	- 4 - 16	- 5 - 16	- 6 - 16	- 7 - 16	- 8 - 16	- 9 - 16	- 10 - 16	1.000
- 2 - 17	- 3 - 17	- 4 - 17	- 5 - 17	- 6 - 17	- 7 - 17	- 8 - 17	- 9 - 17	- 10 - 17	1.062
- 2 - 18	- 3 - 18	- 4 - 18	- 5 - 18	- 6 - 18	- 7 - 18	- 8 - 18	- 9 - 18	- 10 - 18	1.125
- 2 - 19	- 3 - 19	- 4 - 19	- 5 - 19	- 6 - 19	- 7 - 19	- 8 - 19	- 9 - 19	- 10 - 19	1.187
- 2 - 20	- 3 - 20	- 4 - 20	- 5 - 20	- 6 - 20	- 7 - 20	- 8 - 20	- 9 - 20	- 10 - 20	1.250
- 2 - 21	- 3 - 21	- 4 - 21	- 5 - 21	- 6 - 21	- 7 - 21	- 8 - 21	- 9 - 21	- 10 - 21	1.312
- 2 - 22	- 3 - 22	- 4 - 22	- 5 - 22	- 6 - 22	- 7 - 22	- 8 - 22	- 9 - 22	- 10 - 22	1.375
- 2 - 23	- 3 - 23	- 4 - 23	- 5 - 23	- 6 - 23	- 7 - 23	- 8 - 23	- 9 - 23	- 10 - 23	1.437
- 2 - 24	- 3 - 24	- 4 - 24	- 5 - 24	- 6 - 24	- 7 - 24	- 8 - 24	- 9 - 24	- 10 - 24	1.500
- 2 - 25	- 3 - 25	- 4 - 25	- 5 - 25	- 6 - 25	- 7 - 25	- 8 - 25	- 9 - 25	- 10 - 25	1.562
- 2 - 26	- 3 - 26	- 4 - 26	- 5 - 26	- 6 - 26	- 7 - 26	- 8 - 26	- 9 - 26	- 10 - 26	1.625
- 2 - 27	- 3 - 27	- 4 - 27	- 5 - 27	- 6 - 27	- 7 - 27	- 8 - 27	- 9 - 27	- 10 - 27	1.687
- 2 - 28	- 3 - 28	- 4 - 28	- 5 - 28	- 6 - 28	- 7 - 28	- 8 - 28	- 9 - 28	- 10 - 28	1.750

**TABLE 5**

.2500-28 SIZE FIRST DASH NUMBER -4									
G GRIP									L LENGTH
.062	.094	.125	.156	.187	.218	.250	.281	.312	
- 2 - 7	- 3 - 7	- 4 - 7	- 5 - 7	- 6 - 7	- 7 - 7	- 8 - 7	-----	-----	.437
- 2 - 8	- 3 - 8	- 4 - 8	- 5 - 8	- 6 - 8	- 7 - 8	- 8 - 8	- 9 - 8	- 10 - 8	.500
- 2 - 9	- 3 - 9	- 4 - 9	- 5 - 9	- 6 - 9	- 7 - 9	- 8 - 9	- 9 - 9	- 10 - 9	.562
- 2 - 10	- 3 - 10	- 4 - 10	- 5 - 10	- 6 - 10	- 7 - 10	- 8 - 10	- 9 - 10	- 10 - 10	.625
- 2 - 11	- 3 - 11	- 4 - 11	- 5 - 11	- 6 - 11	- 7 - 11	- 8 - 11	- 9 - 11	- 10 - 11	.687
- 2 - 12	- 3 - 12	- 4 - 12	- 5 - 12	- 6 - 12	- 7 - 12	- 8 - 12	- 9 - 12	- 10 - 12	.750
- 2 - 13	- 3 - 13	- 4 - 13	- 5 - 13	- 6 - 13	- 7 - 13	- 8 - 13	- 9 - 13	- 10 - 13	.812
- 2 - 14	- 3 - 14	- 4 - 14	- 5 - 14	- 6 - 14	- 7 - 14	- 8 - 14	- 9 - 14	- 10 - 14	.875
- 2 - 15	- 3 - 15	- 4 - 15	- 5 - 15	- 6 - 15	- 7 - 15	- 8 - 15	- 9 - 15	- 10 - 15	.937
- 2 - 16	- 3 - 16	- 4 - 16	- 5 - 16	- 6 - 16	- 7 - 16	- 8 - 16	- 9 - 16	- 10 - 16	1.000
- 2 - 17	- 3 - 17	- 4 - 17	- 5 - 17	- 6 - 17	- 7 - 17	- 8 - 17	- 9 - 17	- 10 - 17	1.062
- 2 - 18	- 3 - 18	- 4 - 18	- 5 - 18	- 6 - 18	- 7 - 18	- 8 - 18	- 9 - 18	- 10 - 18	1.125
- 2 - 19	- 3 - 19	- 4 - 19	- 5 - 19	- 6 - 19	- 7 - 19	- 8 - 19	- 9 - 19	- 10 - 19	1.187
- 2 - 20	- 3 - 20	- 4 - 20	- 5 - 20	- 6 - 20	- 7 - 20	- 8 - 20	- 9 - 20	- 10 - 20	1.250
- 2 - 21	- 3 - 21	- 4 - 21	- 5 - 21	- 6 - 21	- 7 - 21	- 8 - 21	- 9 - 21	- 10 - 21	1.312
- 2 - 22	- 3 - 22	- 4 - 22	- 5 - 22	- 6 - 22	- 7 - 22	- 8 - 22	- 9 - 22	- 10 - 22	1.375
- 2 - 23	- 3 - 23	- 4 - 23	- 5 - 23	- 6 - 23	- 7 - 23	- 8 - 23	- 9 - 23	- 10 - 23	1.437
- 2 - 24	- 3 - 24	- 4 - 24	- 5 - 24	- 6 - 24	- 7 - 24	- 8 - 24	- 9 - 24	- 10 - 24	1.500
- 2 - 25	- 3 - 25	- 4 - 25	- 5 - 25	- 6 - 25	- 7 - 25	- 8 - 25	- 9 - 25	- 10 - 25	1.562
- 2 - 26	- 3 - 26	- 4 - 26	- 5 - 26	- 6 - 26	- 7 - 26	- 8 - 26	- 9 - 26	- 10 - 26	1.625
- 2 - 27	- 3 - 27	- 4 - 27	- 5 - 27	- 6 - 27	- 7 - 27	- 8 - 27	- 9 - 27	- 10 - 27	1.687
- 2 - 28	- 3 - 28	- 4 - 28	- 5 - 28	- 6 - 28	- 7 - 28	- 8 - 28	- 9 - 28	- 10 - 28	1.750

THIS DRAWING EMBODIES A CONFIDENTIAL, PROPRIETARY DESIGN & ALL DESIGN, MANUFACTURING PRODUCTION, USE & SALE RIGHTS REGARDING SAME ARE EXPRESSLY RESERVED.

INTERIM DOCUMENT REVISION		
Rev.	Date	DAF#
A1	10/8/2018	117431

PROJECT NUMBER: 91-091 S45584

APPROVED DATE <b>4 MAR 91</b>	 CURRENT DESIGN ACTIVITY: Arconic Fastening Systems <b>TRIDAIR PRODUCTS</b> 3000 W. LOMITA BLVD. TORRANCE, CA. 90505	TITLE: <b>SCREW, CAPTIVE, PAN HEAD, CRES, 155 KSI</b>	CURRENT DESIGN ACTIVITY: <b>CAGE CODE: 29372</b>
REV. LETTER AND DATE <b>A 19 JUL 16</b>		UNLESS OTHERWISE SPECIFIED DIMENSIONS ARE IN INCHES & ASME Y14.5M TOLERANCES:	SALES DRAWING NO.
DAF NUMBER <b>DAF 114634</b>		ANGLES = ±3° DECIMALS .XX = ±.02 .XXX = ±.010	<b>CA2228-()-()-()</b>
			SHEET 3 OF 4

MANUFACTURE OF THE PROPRIETARY PARTS SHOWN HERE WITHOUT WRITTEN CONSENT IS ABSOLUTELY PROHIBITED

**TABLE 6**

.3125-24 SIZE FIRST DASH NUMBER -5									
G GRIP									L
.062	.094	.125	.156	.187	.218	.250	.281	.312	LENGTH
- 2 - 7	- 3 - 7	- 4 - 7	- 5 - 7	- 6 - 7	- 7 - 7	-----	-----	-----	.437
- 2 - 8	- 3 - 8	- 4 - 8	- 5 - 8	- 6 - 8	- 7 - 8	- 8 - 8	- 9 - 8	-----	.500
- 2 - 9	- 3 - 9	- 4 - 9	- 5 - 9	- 6 - 9	- 7 - 9	- 8 - 9	- 9 - 9	- 10 - 9	.562
- 2 - 10	- 3 - 10	- 4 - 10	- 5 - 10	- 6 - 10	- 7 - 10	- 8 - 10	- 9 - 10	- 10 - 10	.625
- 2 - 11	- 3 - 11	- 4 - 11	- 5 - 11	- 6 - 11	- 7 - 11	- 8 - 11	- 9 - 11	- 10 - 11	.687
- 2 - 12	- 3 - 12	- 4 - 12	- 5 - 12	- 6 - 12	- 7 - 12	- 8 - 12	- 9 - 12	- 10 - 12	.750
- 2 - 13	- 3 - 13	- 4 - 13	- 5 - 13	- 6 - 13	- 7 - 13	- 8 - 13	- 9 - 13	- 10 - 13	.812
- 2 - 14	- 3 - 14	- 4 - 14	- 5 - 14	- 6 - 14	- 7 - 14	- 8 - 14	- 9 - 14	- 10 - 14	.875
- 2 - 15	- 3 - 15	- 4 - 15	- 5 - 15	- 6 - 15	- 7 - 15	- 8 - 15	- 9 - 15	- 10 - 15	.937
- 2 - 16	- 3 - 16	- 4 - 16	- 5 - 16	- 6 - 16	- 7 - 16	- 8 - 16	- 9 - 16	- 10 - 16	1.000
- 2 - 17	- 3 - 17	- 4 - 17	- 5 - 17	- 6 - 17	- 7 - 17	- 8 - 17	- 9 - 17	- 10 - 17	1.062
- 2 - 18	- 3 - 18	- 4 - 18	- 5 - 18	- 6 - 18	- 7 - 18	- 8 - 18	- 9 - 18	- 10 - 18	1.125
- 2 - 19	- 3 - 19	- 4 - 19	- 5 - 19	- 6 - 19	- 7 - 19	- 8 - 19	- 9 - 19	- 10 - 19	1.187
- 2 - 20	- 3 - 20	- 4 - 20	- 5 - 20	- 6 - 20	- 7 - 20	- 8 - 20	- 9 - 20	- 10 - 20	1.250
- 2 - 21	- 3 - 21	- 4 - 21	- 5 - 21	- 6 - 21	- 7 - 21	- 8 - 21	- 9 - 21	- 10 - 21	1.312
- 2 - 22	- 3 - 22	- 4 - 22	- 5 - 22	- 6 - 22	- 7 - 22	- 8 - 22	- 9 - 22	- 10 - 22	1.375
- 2 - 23	- 3 - 23	- 4 - 23	- 5 - 23	- 6 - 23	- 7 - 23	- 8 - 23	- 9 - 23	- 10 - 23	1.437
- 2 - 24	- 3 - 24	- 4 - 24	- 5 - 24	- 6 - 24	- 7 - 24	- 8 - 24	- 9 - 24	- 10 - 24	1.500
- 2 - 25	- 3 - 25	- 4 - 25	- 5 - 25	- 6 - 25	- 7 - 25	- 8 - 25	- 9 - 25	- 10 - 25	1.562
- 2 - 26	- 3 - 26	- 4 - 26	- 5 - 26	- 6 - 26	- 7 - 26	- 8 - 26	- 9 - 26	- 10 - 26	1.625
- 2 - 27	- 3 - 27	- 4 - 27	- 5 - 27	- 6 - 27	- 7 - 27	- 8 - 27	- 9 - 27	- 10 - 27	1.687
- 2 - 28	- 3 - 28	- 4 - 28	- 5 - 28	- 6 - 28	- 7 - 28	- 8 - 28	- 9 - 28	- 10 - 28	1.750

**TABLE 7**

.3750-24 SIZE FIRST DASH NUMBER -6									
G GRIP									L
.062	.094	.125	.156	.187	.218	.250	.281	.312	LENGTH
- 2 - 7	- 3 - 7	- 4 - 7	- 5 - 7	- 6 - 7	- 7 - 7	-----	-----	-----	.437
- 2 - 8	- 3 - 8	- 4 - 8	- 5 - 8	- 6 - 8	- 7 - 8	- 8 - 8	- 9 - 8	-----	.500
- 2 - 9	- 3 - 9	- 4 - 9	- 5 - 9	- 6 - 9	- 7 - 9	- 8 - 9	- 9 - 9	- 10 - 9	.562
- 2 - 10	- 3 - 10	- 4 - 10	- 5 - 10	- 6 - 10	- 7 - 10	- 8 - 10	- 9 - 10	- 10 - 10	.625
- 2 - 11	- 3 - 11	- 4 - 11	- 5 - 11	- 6 - 11	- 7 - 11	- 8 - 11	- 9 - 11	- 10 - 11	.687
- 2 - 12	- 3 - 12	- 4 - 12	- 5 - 12	- 6 - 12	- 7 - 12	- 8 - 12	- 9 - 12	- 10 - 12	.750
- 2 - 13	- 3 - 13	- 4 - 13	- 5 - 13	- 6 - 13	- 7 - 13	- 8 - 13	- 9 - 13	- 10 - 13	.812
- 2 - 14	- 3 - 14	- 4 - 14	- 5 - 14	- 6 - 14	- 7 - 14	- 8 - 14	- 9 - 14	- 10 - 14	.875
- 2 - 15	- 3 - 15	- 4 - 15	- 5 - 15	- 6 - 15	- 7 - 15	- 8 - 15	- 9 - 15	- 10 - 15	.937
- 2 - 16	- 3 - 16	- 4 - 16	- 5 - 16	- 6 - 16	- 7 - 16	- 8 - 16	- 9 - 16	- 10 - 16	1.000
- 2 - 17	- 3 - 17	- 4 - 17	- 5 - 17	- 6 - 17	- 7 - 17	- 8 - 17	- 9 - 17	- 10 - 17	1.062
- 2 - 18	- 3 - 18	- 4 - 18	- 5 - 18	- 6 - 18	- 7 - 18	- 8 - 18	- 9 - 18	- 10 - 18	1.125
- 2 - 19	- 3 - 19	- 4 - 19	- 5 - 19	- 6 - 19	- 7 - 19	- 8 - 19	- 9 - 19	- 10 - 19	1.187
- 2 - 20	- 3 - 20	- 4 - 20	- 5 - 20	- 6 - 20	- 7 - 20	- 8 - 20	- 9 - 20	- 10 - 20	1.250
- 2 - 21	- 3 - 21	- 4 - 21	- 5 - 21	- 6 - 21	- 7 - 21	- 8 - 21	- 9 - 21	- 10 - 21	1.312
- 2 - 22	- 3 - 22	- 4 - 22	- 5 - 22	- 6 - 22	- 7 - 22	- 8 - 22	- 9 - 22	- 10 - 22	1.375
- 2 - 23	- 3 - 23	- 4 - 23	- 5 - 23	- 6 - 23	- 7 - 23	- 8 - 23	- 9 - 23	- 10 - 23	1.437
- 2 - 24	- 3 - 24	- 4 - 24	- 5 - 24	- 6 - 24	- 7 - 24	- 8 - 24	- 9 - 24	- 10 - 24	1.500
- 2 - 25	- 3 - 25	- 4 - 25	- 5 - 25	- 6 - 25	- 7 - 25	- 8 - 25	- 9 - 25	- 10 - 25	1.562
- 2 - 26	- 3 - 26	- 4 - 26	- 5 - 26	- 6 - 26	- 7 - 26	- 8 - 26	- 9 - 26	- 10 - 26	1.625
- 2 - 27	- 3 - 27	- 4 - 27	- 5 - 27	- 6 - 27	- 7 - 27	- 8 - 27	- 9 - 27	- 10 - 27	1.687
- 2 - 28	- 3 - 28	- 4 - 28	- 5 - 28	- 6 - 28	- 7 - 28	- 8 - 28	- 9 - 28	- 10 - 28	1.750

THIS DRAWING EMBODIES A CONFIDENTIAL, PROPRIETARY DESIGN & ALL DESIGN, MANUFACTURING PRODUCTION, USE & SALE RIGHTS REGARDING SAME ARE EXPRESSLY RESERVED.

PROJECT NUMBER: 91-091  
S45584

INTERIM DOCUMENT REVISION		
Rev.	Date	DAF#
A1	10/8/2018	117431

APPROVED DATE <b>4 MAR 91</b>	CURRENT DESIGN ACTIVITY:  <b>ARCONIC</b> Arconic Fastening Systems	TITLE: <b>SCREW, CAPTIVE, PAN HEAD, CRES, 155 KSI</b>	CURRENT DESIGN ACTIVITY: <b>CAGE CODE: 29372</b>
REV. LETTER AND DATE <b>A 19 JUL 16</b>	<b>TRIDAIR PRODUCTS</b> 3000 W. LOMITA BLVD. TORRANCE, CA. 90505	UNLESS OTHERWISE SPECIFIED DIMENSIONS ARE IN INCHES & ASME Y14.5M TOLERANCES:	<b>SALES DRAWING NO.</b>
DAF NUMBER <b>DAF 114334</b>			<b>CA2228-()-()-()</b>
		ANGLES = ±3° DECIMALS .XX = ±.02 .XXX = ±.010	<b>SHEET 4 OF 4</b>